

# SANIACCESS<sup>®</sup> 2 Macerator

INSTALLATION BEHIND THE TOILET

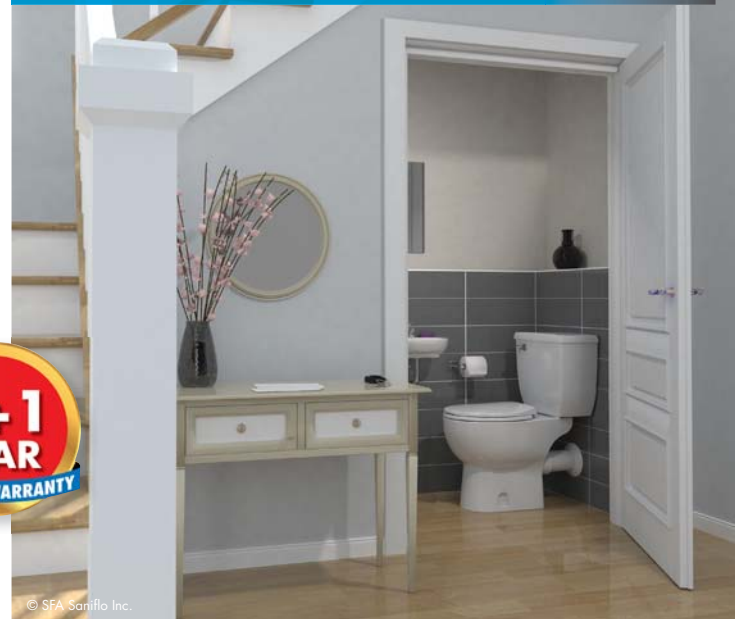

INSTALLATION BEHIND THE WALL



The Saniaccess2 is a 1/2 HP pump system used to install a half-bathroom up to 15 feet below the sewer line, or even up to 150 feet away from a soil stack. It incorporates a macerating system which can handle human waste and toilet paper in residential applications. The blade is made out of a hardened stainless steel material which eliminates the need for any service or replacement.

- Discharges the waste through a 3/4" or 1" rigid pipe. A non-return valve is included on the discharge elbow assembly provided with the system. This elbow can be rotated 360 degrees depending on the discharge installation.
- Has been designed with a 1 1/2" vent connection on the side of the pump housing. All plumbing codes require connection to a vent system. Please note that the vent system should be a two-way air vent as air needs to freely flow both ways. Note: The use of mechanical vents, air admittance valves or similar devices is not permitted.
- Must be connected to Saniflo's 1.28 GPF rear discharge toilet. These toilets come in round and elongated (ADA compliant) models. More technical information on page 5.
- Will also discharge gray water from a sink. The wastewater will drain into the system via a 1 1/2" inlet which is located on the side of the pump housing. Note that either side connection can be used for the vent or as an inlet.
- Designed with two easy access service panels located on top of the pump. On one side of the pump you can easily access the electrical components and the level sensor. The other side allows access to the macerating blade for easy removal of foreign objects.



## TECHNICAL SPECIFICATIONS

**Pump type:** Macerator

**Electrical:** 120 V – 60 Hz / 4.5 Amps (Max)

**Motor:** 0.5 HP oil-filled thermally protected motor

**Capacitor rating:** 45 microfarad

**Operating Temperature:** 104°F (110°F Max.)

**Power cord length:** 51 inches

**Noise level:** ≤ 53 dBA (Lp) (measured at 3 ft.)



**Discharge pipe diameter:** ¾" or 1"

**Discharge rate at 15 ft:** 17 GPM

**Discharge rate at 3 ft:** 27 GPM

**Shut-off head:** 30 ft.

**Normal running time:** 10-12s

**Capacity:** 2.3 gallons

**Inlets:** 1½" (side), 1½" vent (side)

**Method of activation:** Membrane/microswitch

**Weight:** 15 lbs.

**Certifying agencies:** CSA (IPC, NSPC), IAPMO (UPC)

**Recommended accessories:** Descaler

**Connections:** Rear outlet toilet, sink

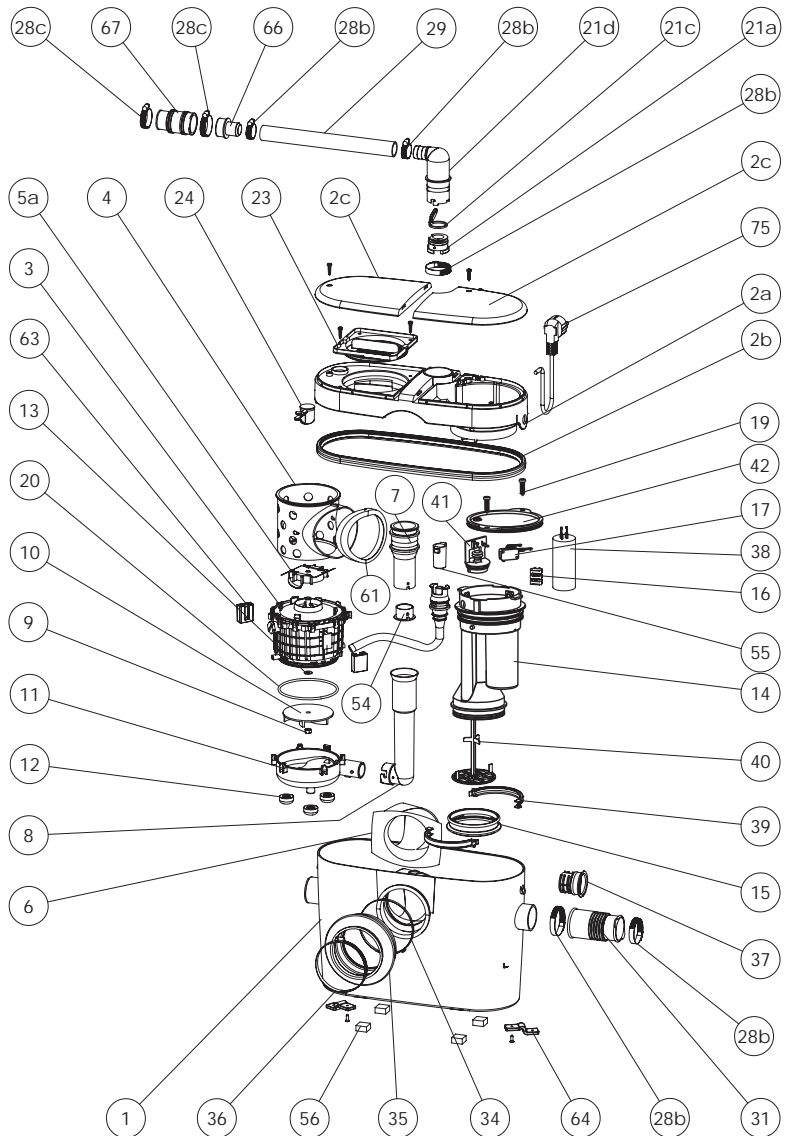
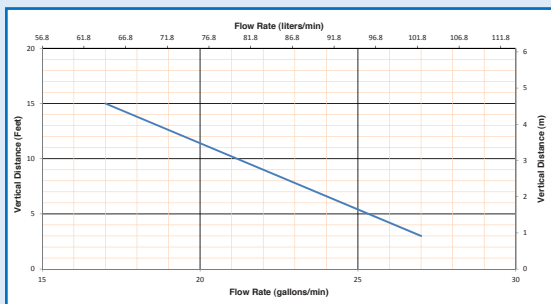
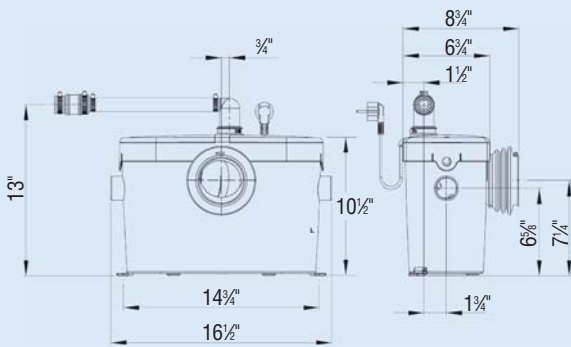

**PLEASE CALL US TOLL-FREE AT 800-571-8191 (US) / 800-363-5874 (CDN) TO PURCHASE PARTS REFERENCED ABOVE**

## Round/Elongated Bowl

(Part No. 083 or 087)

Rear discharge toilet with 16¾" seating height (Elongated bowl is ADA compliant). For more information, please turn to page 5.

## Extension Pipe (Part No. 030)

18" long PVC pipe with internal gasket used to hide the pump behind the wall. For more information, please turn to page 48.

# SANIACCESS® 2

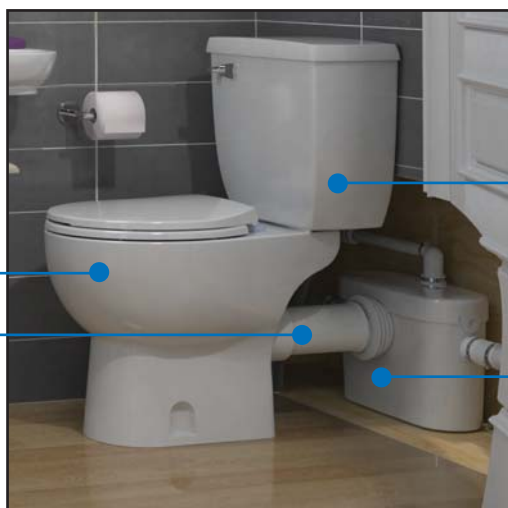

## Toilet Tank (Part No. 005)

Insulated 1.28 GPF toilet tank equipped with all internal valves. For more information, please turn to page 5.

## Saniaccess2 (Part No. 081)

Macerating pump for residential applications. Ideal for creating a half-bathroom in a basement, attic, garage, pool house, etc.

**Choose any sink and enjoy your dream half-bathroom.**