

# SANICUBIC® 1 Grinder

## INSTALLATION ABOVE THE GROUND



© SFA Saniflo Inc.

Example of installation. Follow local plumbing codes for actual install.

## INSTALLATION BELOW THE GROUND



© SFA Saniflo Inc.

Example of installation. Follow local plumbing codes for actual install.



The **Sanicubic 1** is a **1 HP heavy duty simplex grinder system** used to pump away waste water from several bathrooms and fixtures from an entire building structure. This system is able to discharge the waste up to **36 feet vertical and/or 328 feet horizontal**. It incorporates a grinder system which is ideal for uncontrolled environments in both residential and commercial applications (ie. rental unit, offices, warehouses, etc). The Sanicubic 1 is designed **to handle sanitary products** that may have been flushed down the toilet; such may consist of condoms, sanitary napkins, q-tips, dental floss, etc.

- **Discharges the waste through a 1½" rigid pipe.** A built-in non-return valve is included on the internal discharge pipe.
- Has been designed with a **1½" vent connection** on the top of the enclosure. All plumbing codes require connection to a vent system. Please note that the vent system should be a two-way air vent as air needs to freely flow both ways. Note: The use of mechanical vents, air admittance valves or similar devices is not permitted.
- **The Sanicubic 1 is IP68** rated for possible submergence which eliminates any potential water damage to internal components. It comes equipped with an external control panel as well as a visual and audible alarm system (15 ft. long wire).
- The pump discharges wastewater from **several toilets, sinks, bath/showers, urinals and even washing machines**. The wastewater from other sanitary fixtures is drained into the Sanicubic 1 **via four 1½" or 4" inlets** on either side of the housing and on top of the enclosure. Note that when draining waste water into the pump through either of the side inlets, an external check valve (not supplied) has to be installed. Also, note that there should be a minimum 10" height difference between the base of the Sanicubic 1 to the bottom of the shower/bathtub drain or to the base of the toilet.

220 VOLT  
VERSION  
Available  
Summer  
2018

## TECHNICAL SPECIFICATIONS

**Pump type:** Grinder

**Electrical:** 120 V – 60 Hz / 10 Amps (Max)

**Motor:** 1 HP oil-filled thermally protected motor

**Capacitor rating:** 60 microfarad

**Operating Temperature:** 158°F Max.

**Power cord length:** 80 inches

**Noise level:** ≤ 68 dBA (Lp) (measured at 3 ft.)



**SANICUBIC 1 • PART NO. 089**





**Discharge pipe diameter:** 1 1/2"

**Discharge rate at 36 ft:** 26 GPM

**Discharge rate at 3 ft:** 50 GPM

**Shut-off head:** 45 ft.

**Normal running time:** Depends on number of fixtures

**Capacity:** 8.5 gallons

**Inlets:** 1 1/2" or 4" (sides), 1 1/2" or 4" (top)

**Method of activation:** Pressure switch, circuit board

**Toilet, shower/bathtub base height:** 10" min

**Weight:** 50 lbs.

**Certifying agencies:** CSA (IPC, NSPC), IAPMO (UPC)

**Recommended accessories:** Descaler

**Connections:** Toilets, sinks, shower/bathtubs, washing machines (direct connection), etc.

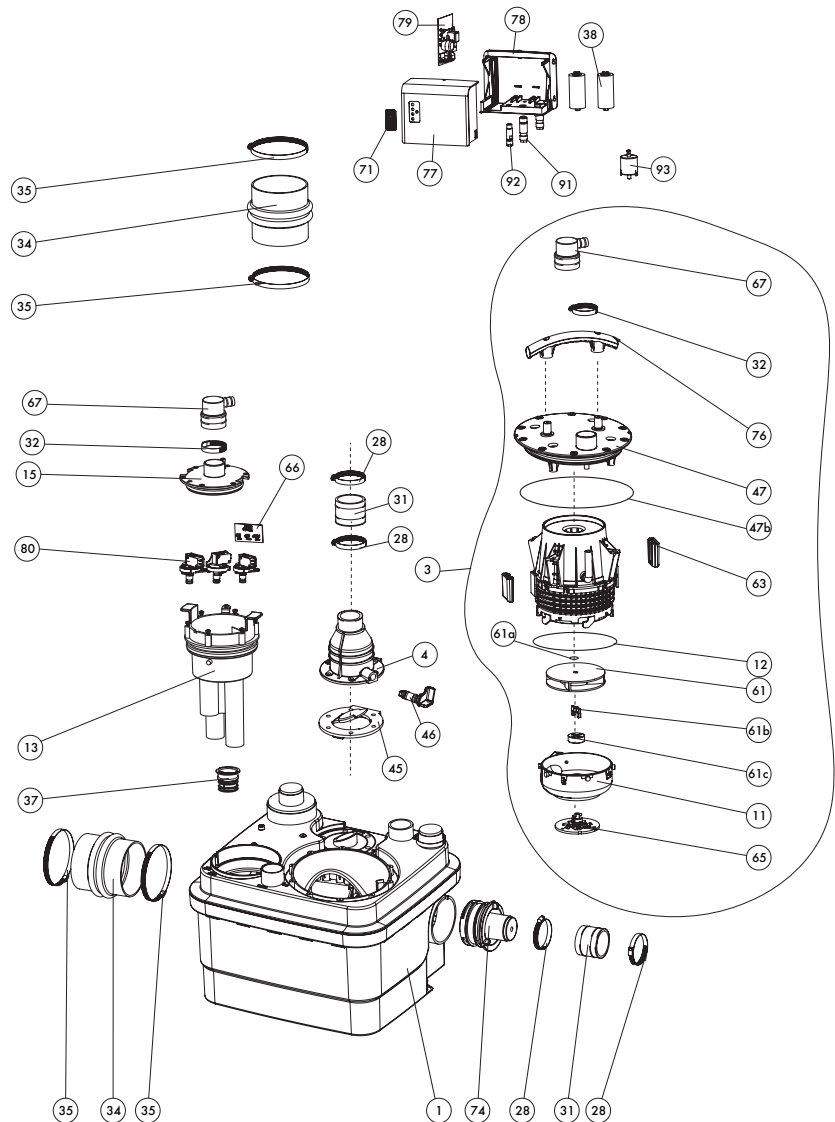
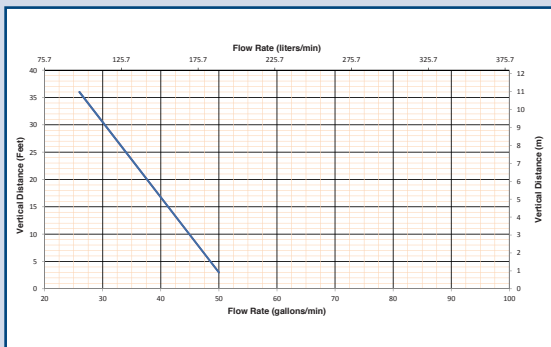
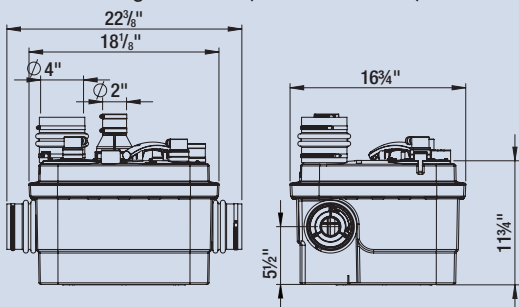

**PLEASE CALL US TOLL-FREE AT 800-571-8191 (US) / 800-363-5874 (CDN) TO PURCHASE PARTS REFERENCED ABOVE**

### PRE-ASSEMBLED GRINDING SYSTEM CAPABLE OF DISCHARGING WASTEWATER FROM MULTIPLE FIXTURES

System can be installed **above the floor, inside a pit or even retrofitted into an existing sewage ejector basin** (at least 24" diameter).

Powerful 1 HP motor for absolute reliability and efficiency that can handle up to **50 gallons per minute from several fixtures.**

System is capable of handling **multiple fixtures simultaneously.** New grinding technology can handle feminine hygiene products and eliminates clogging issues common with sewage ejector stations.



Scan with your smartphone to watch a clip of the Sanicubic 1 system

**FOR ADDITIONAL TECHNICAL QUESTIONS, PLEASE CALL 800-571-8191**